

INSTALLATION INSTRUCTIONS

Description:	Tachometer	Part Number:	990C0-80000/80100
Applications:	Suzuki Marine Boats	Installation Time:	1 HRS
NOTE:	Mounts in standard 3 3/8" hole.	Weight:	1 lbs

Contents

Ref.	Part Number	Description	QTY
1.	990C0-80000/80100	Tachometer	1
2.	BC0146	Mounting Bracket	1
3.	Mounting Hardware		1

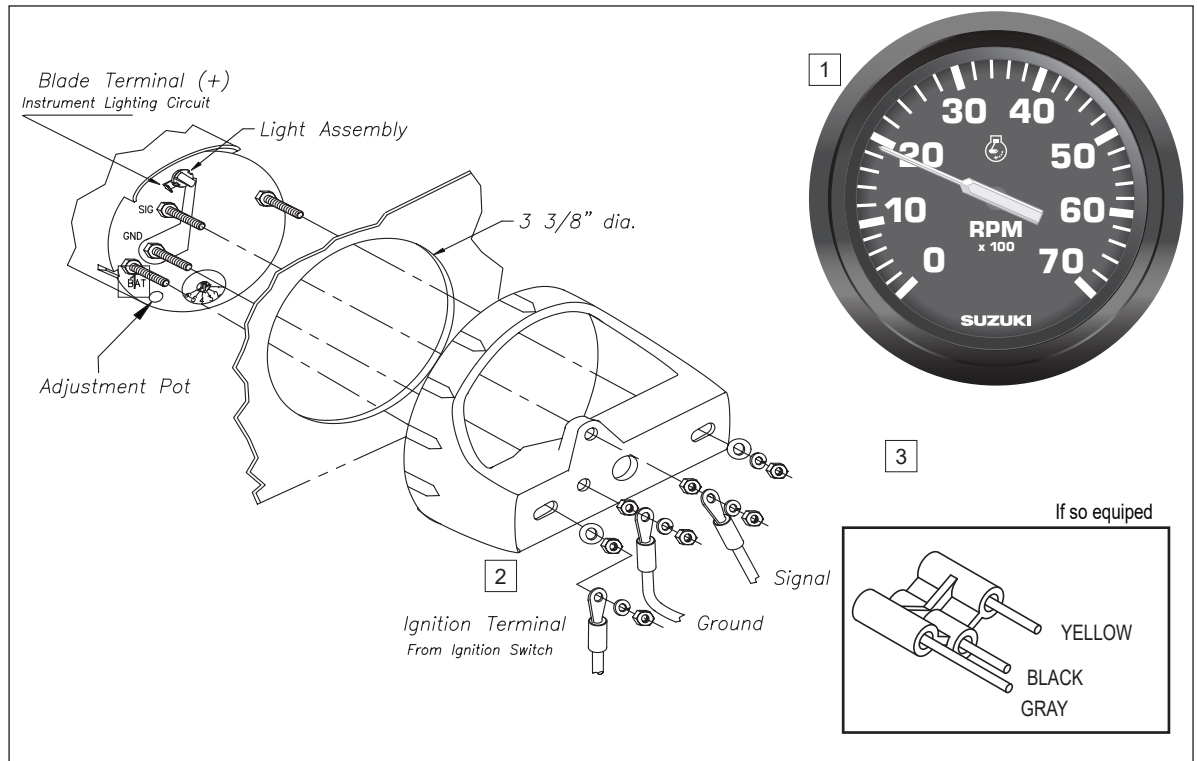

Tools Required

Ref.	Tools Description
1.	3/8" Nut Driver
2.	Suzuki Terminal Kit 09900-28701



Important

- ⚠ WARNING**
- ⚠ CAUTION**
- NOTE**

Please read this manual and follow its instructions carefully. To emphasize special information, the symbol **⚠** and the words **WARNING**, **CAUTION** and **NOTE** have special meanings. Pay special attention to the messages highlighted by these signal words:

NOTE: Indicates special information to make maintenance easier or instructions clear.

⚠ WARNING
Indicates potential hazard that could result in death or injury.

⚠ CAUTION
Indicates potential hazard that could result in vehicle damage.



CAUTION

- Disconnect battery during installation.
- Tighten nuts on backclamp only slightly more than you can tighten with your fingers. Six inch-pounds of torque is sufficient. Over tightening may result in damage to the instrument and may void your warranty.
- Gasket cement or other adhesive is not required to secure tubing to fittings.

Installation

1. Location: The tachometer should be located at least 18" from a magnetic compass. Some interference (erratic operation) may be noticed on the tachometer during radio transmissions. This will neither damage the tachometer nor affect accuracy when not transmitting.

2. It is recommended that you use the included color coded wire extension leads.

3. Using a small screwdriver, SLIGHTLY depress and turn the selector switch on the back of the tachometer to the correct position to match the number of poles in the alternator (see label on the side of the tachometer). Depressing the switch too hard may cause damage to the tachometer! Be sure the selector switch has locked into the detent at the correct position by slightly rotating the switch back and forth with the screwdriver. If the number of poles is not known, consult the "Outboard Tachometer Application" chart or call Faria Beede Instruments at (860) 848-9271 with make, model, HP, and year of the motor.

4. Cut a 3-3/8" dia hole in the dash and mount the tachometer with the backclamp supplied.

5. If this gauge kit has been supplied with a three prong connector, slide the connector over the three instrument studs. Be sure the gray, yellow, and black bullets are connected to the gray, yellow, and black wires of the main engine harness.

6. Connect the gray extension lead stud connector to the positive (+) post of the tachometer and plug the bullet end into the gray wire of the main engine harness.

7. Connect the yellow extension lead stud connector to the signal (SIG) post terminal of the tachometer and plug the bullet end into the yellow wire of the main engine harness.

8. Connect the black extension lead stud connector to the negative (-) post of the tachometer and plug the bullet end into the black wire of the main engine harness.

** (WHEN A STANDARD SIDE MOUNT REMOTE CONTROL IS USED, THE YELLOW TACH SIGNAL, SWITCHED POWER GRAY AND BLACK GROUND

Mounting Hardware Kit



A		x 5
B		x 7
C		x 2

Figure 1



WIRES CAN BE FOUND AT THE CONTROL BOX.)

9. Connect the GREEN/ORANGE extension lead to the blade terminal adjacent to the twist-out light assembly to the positive "+" side of the instrument lighting circuit and the bullet end to the boat lighting circuit. No separate ground is required for the lighting. Reconnect the battery.

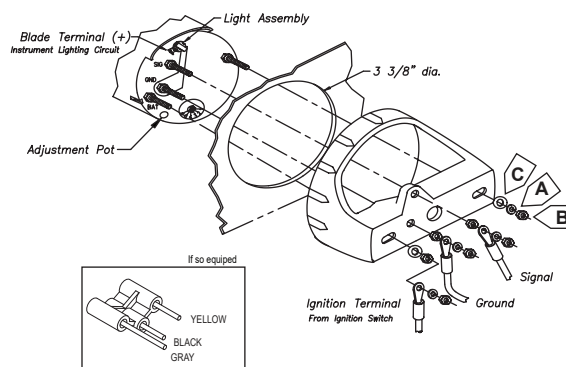
NOTE:

A.) To change light bulb, twist black socket assembly one-eighth turn counterclockwise until it pops out. Bulb pulls straight out of assembly. It is a GE No. 194 instrument lamp.

B.) If your Tachometer is equipped with an hourmeter, the hourmeter will be energized when the engine is running.

Harness Diagram

HN0412 rev A ecr 5609 8/05

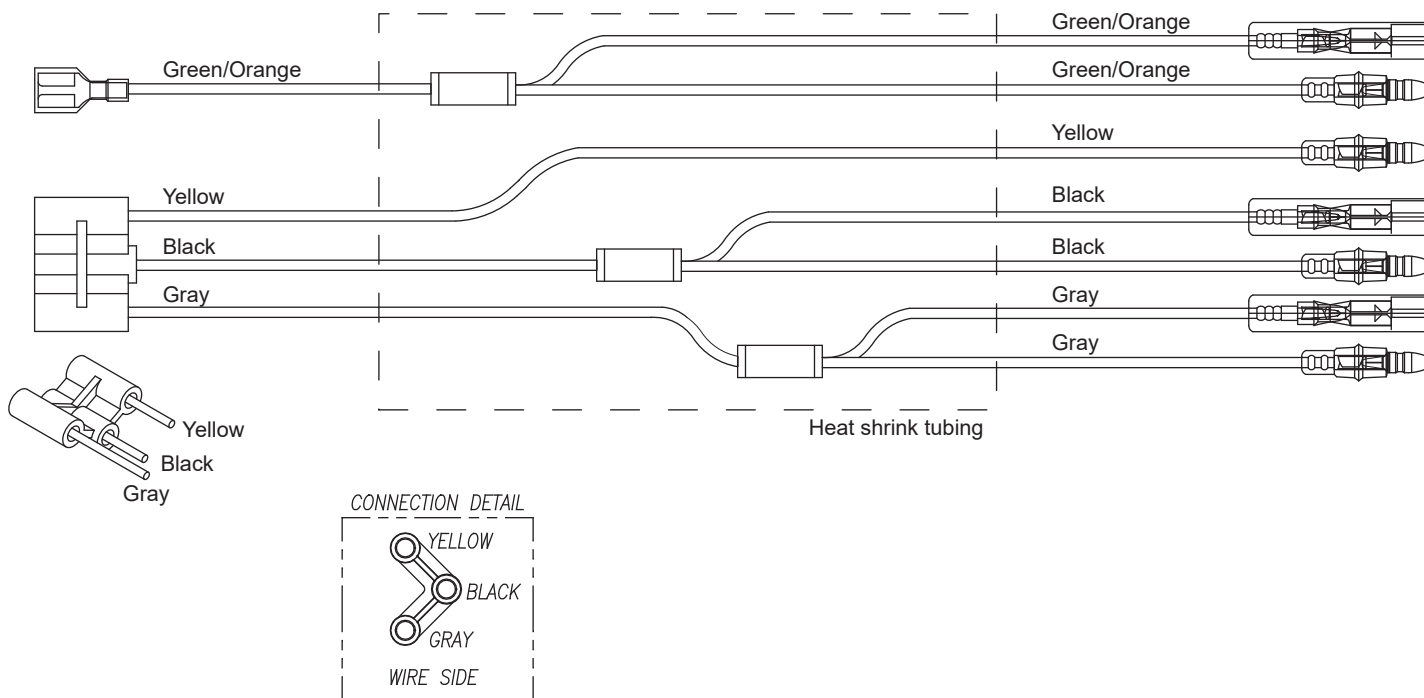

Trouble Shooting

Trouble	Inspection	Diagnosis	Action
Gauge Sticks	A. Backclamp may be too tight.	1. Slightly loosen nuts holding backclamp. Check operation.	1. If gauge works and is not loose in panel, continue using gauge. 2. If gauge continues to stick, replace gauge.
Gauge Inoperative	A. Is power applied to gauge?	1. Switch the instrument power supply switch on and off. As power is supplied the pointer should jump slightly.	1. Check wires to check they were installed on the correct terminals and power is actually supplied to gauge. 2. If pointer jumps (indicating power supplied), check for signal from engine. If signal exists, replace tachometer.

Trouble shooting continued next page.



Trouble Shooting

Trouble	Inspection	Diagnosis	Action
Gauge is Erratic	A. Inspect the connection between the wire and the ring connector.	1. Check for insulation that may have been pushed into connection.	1. Fix connection.
	B. Check for excessive electrical noise caused by an electrical appliance set to close to the gauge. i.e. a magnetic compass, a radio transmission.	1. Check wires by connecting one wire at a time to the tachometer directly from the battery or the signal source on the engine.	1. Relocate offensive appliance. Please refer to installation instructions.
	C. A reading of Hi or Low may be the cause of alternator pole switch not selected correctly.	1. Check the switch on the back of the tachometer. Refer to chart on the next page.	1. If the tachometer reads to high, then the switch is selected too low. 2. If the tachometer reads too low, then the switch is selected too high.

Outboard Tachometer Application Chart

Make/ Year	Model	# of Poles.
Suzuki through 2006 All Suzuki 4-strokes, DF40 and larger, will require a Tach/System Monitor or 2" System Monitor gauge to properly indicate any warning or diagnostic event.	Less than 55 HP - All 60 HP, 65 HP thru 1985 50 - 60 HP Cabrea	4
	DF 4 through 30 (4 stroke) 25 HP & 30 HP (1993 & later) 55 HP & 65 HP (1985 & later)	6
	75 HP & up (1985 & later) 75 HP and up (Cabrea) 115 HP and up (1988 & later) DF 40 through DF 250, DFV6 (4 stroke)	12