

Garmin®

**MARINE
INSTRUMENTS**



Owner's Manual

MG2000 Speedometer

for use with SmartCraft™ Tachometer

IS0211

rev. E ecr#6395 08/2006

4/5/05

Changes 12/21

Description

| | |
|-----------------------------------|---------|
| Available Functions for display | page 1 |
| Default Screens | page 1 |
| Figure 1 | page 2 |
| Description | page 2 |
| Normal Mode | page 3 |
| Contrast and Lighting | page 3 |
| Displayed Functions | page 4 |
| Figure 2 - Select Mode | page 6 |
| Figure 3 - LCD Display Screens | page 7 |
| Fuel Functions | page 8 |
| Fuel Level Sender | page 8 |
| Manual Settings | page 8 |
| COG (Course Over Ground) | page 9 |
| Edit Mode | page 11 |
| Select "Default Screen" | page 12 |
| Reset "Trip Log" | page 12 |
| Organize User Screens | page 12 |
| Organize Screen 1 | page 13 |
| Select "Adjust Clock Offset" | page 14 |
| Select "Enable Display Screens" | page 14 |
| Select "Set Clock Type" | page 14 |
| Select "Set GPS COG Display" | page 15 |
| Select "Self Test" | page 15 |
| Select "Software Id And Revision" | page 16 |
| Alarm Mode | page 17 |
| Figure 4 - Alarm Screen | page 17 |
| Low Fuel - Low Oil | page 17 |
| Harness - HN0403 | page 19 |
| Harness - HN0407 | page 21 |
| 2 inch Gauge connection | page 22 |

This page left blank intentionally.

FARIA® MG2000 Speedometer Manual

The FARIA® MG2000 speedometer combines the features of a speedometer and several digital instruments into one unit:

- The MG2000 speedometer pointer is analog in appearance but is driven by a stepper motor for digital accuracy.



- The high resolution LCD screen displays information for many other functions and the various “screens” can be configured as the user wishes. As received, the screens are configured as shown in Fig. 1.



The MG2000 speedometer receives digital data via the Faria Serial Bus from the MG2000 tachometer. An analog input is provided for a sensor for air temperature.

The Faria MG2000 speedometer will turn on when the ignition key is turned on and will turn off when the ignition key is turned off.

The unit will power up showing the default screen selected by the user.

Available functions for display in MG2000 speedometer screens

The functions listed below can be displayed in the user configured screens. All of the functions may not be available in your installation. If a function is selected for display and that function does not appear on the screen, the function does not exist in this installation.

1. GPS Clock
2. Fuel Level (bar graph)
3. Fuel Left
4. GPS Heading
5. GPS Lat and Long
6. GPS Speed
7. Air Temperature (Analog input to MG2000 Speedometer from air temp sender)
8. Sea Temperature
9. Speed
10. Inst Econ(omy)
11. Avg Econ(omy)
12. Estimated Range
13. Avg Fuel Flow
14. Fuel Used
15. Trip miles
16. Steer Angle

Default Screen 1

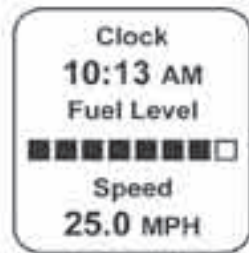

Other default screens:

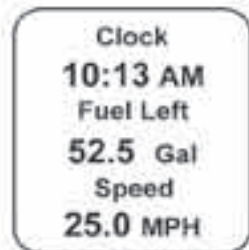



Note: The GPS data shown on the Faria® MG2000 is for reference only and is not meant to be used as a navigational device.



Description

The instrument has three push buttons; “Down”, **M** “Mode”, and “Up”; that control the functions available.



The **M** “Mode” button is used to change the function of the LCD display and to access submenus and adjustable settings.



The “Down” and “Up” buttons are used to modify the settings.



In the normal operation mode, pressing the **M** “Mode” button and then pressing “Down” or “Up” causes the display to cycle between the available screens.

*Press the **M** “Mode” button to exit the “Screen Selection” mode and return to the normal mode or if no button is pushed for 4 seconds the current screen will stay selected and the unit will automatically return to the normal mode. (see **Figure 2**).*



From the “Normal” mode, press the **M** “Mode” and “Up” buttons to change to the

“Edit” menus (See Figure 3).



When “Edit” menus have been selected, press the **M** “Mode” button for the instrument to return to normal mode.



Press the “Down” or “Up” to cycle between the available “Edit” functions.



Press and hold the “Down” and “Up” buttons for two (2) seconds to select an “Edit” function to change.



Within each “Editing” function the “Down” or “Up” buttons select settings or sub-functions. Follow the instructions in the “Edit” mode section of this manual to save the new settings after you select / adjust them.

Normal Mode

When the MG2000 speedometer is turned on, the unit enters “Self Test” mode. The screen will display “Self Test Faria MG2000 SW ID + Rev. PGFXXXXX Date” for 12 seconds.

The backlights and warning lights will

flash three times. When this is complete, the user selected “Default” screen will appear.

The information below applies to the MG2000 speedometer as received with no user changes to the screen selections.

Contrast and Lighting

In the “Normal” operating mode the instrument display contrast and display mode can be adjusted by pressing the “Down” and “Up” buttons.



With the display in “Positive” mode, black on white, pressing the “Down” button decreases the contrast. Pressing the “Up” button increases contrast.

Continuing to press the “Up” button causes the display to reverse to the “Negative” mode, white on black. The contrast in this mode is controlled the same way as the “Positive” mode.

To return to “Positive” mode, continue to press the “Down” button until the display reverses.

To adjust the lighting intensity of all of the instruments in the system, press and hold both the “Down” and “Up” buttons for 2 seconds. The lighting intensity may now be adjusted by using the “Down” or “Up” buttons.



Return to the “Normal” mode by pressing and holding both the “Down” and “Up” buttons for 2 seconds.

MG2000 speedometer displayed functions

Default Screen “1”



Clock

Displays time received from the GPS NMEA0183 signal (if installed and connected). The display will be in 12 or 24 hour format based on the “Set Clock Type” setting selected in the “Edit” mode.

Fuel Level

Displays fuel level in Tank 1 as received from the MG2000 SmartCraft tachometer from the engine ECU. This is fuel level sender information. The fuel level sender should be calibrated as described in the Faria SmartCraft MG2000 tachometer manual.

Speed

Displays current speed in water from the installed pitot tube and/or paddle wheel as received from the MG2000 SmartCraft tachometer from the engine ECU.

Default Screen “2”



Clock

Displays time received from the GPS NMEA0183 signal (if installed and connected). The display will be in 12 or 24 hour format based on the “Set

Clock Type” setting selected in the “Edit” mode.

Fuel Left

Displays the calculated amount of fuel left in Tank 1. This display shows the calculated amount of fuel remaining based on the fuel information entered by the operator minus the fuel used as calculated from the “Gal Per Hour” data received from the engine ECU.

For this function to provide correct information the operator MUST set “Fuel Tank Size”, “Fuel Tank Full” or “Amount of Fuel” in the MG2000 tachometer edit menu. This display is NOT information from the fuel level sender and must be used carefully.

Speed

Displays current speed in water from the installed pitot tube and/or paddle wheel as received from the MG2000 SmartCraft tachometer from the engine ECU.

Default Screen “3”



COG (Course Over Ground)

Displays the GPS heading received from the GPS NMEA0183 signal (if installed and connected). The display will be in “True” or “Mag” heading based on the “set GPS COG display” setting selected in the “Edit” mode.

If magnetic bearing is not available from the GPS unit, the operator will be unable to select “Mag” in the “Set GPS COG Display” function. In addition, the screen display will change to:



The display will continuously flash at a slow rate to ensure that the operator is aware that the displayed COG is being presented in relation to **TRUE NORTH** not magnetic north!

Lat Long

Displays the GPS Latitude and Longitude of the current location received from the GPS NMEA0183 signal (if installed and connected).

GPS Speed

Displays GPS (SOG) speed received from the GPS NMEA0183 signal (if installed and connected).

Note: The GPS data shown on the Faria® MG2000™ is for reference only and is not meant to be used as a navigational device.

Default Screen “4”



Air Temp

Analog input. Displays current air temperature (if sensor is installed and connected), (displays -4.0° F if the air temperature sensor is not installed or connected).

Sea Temp

Displays current sea or lake water temperature as received from the MG2000 SmartCraft tachometer from the engine ECU.

Speed

Displays current speed in water from the installed pitot tube and/or paddle wheel as received from the MG2000 SmartCraft tachometer from the engine ECU.

Default Screen “5”



Inst Econ

Displays calculated instantaneous fuel economy based on current Gal Per Hour and vehicle speed as received from the MG2000 SmartCraft tachometer from the engine ECU.

Avg Econ

Displays calculated average fuel economy for this period of continuous operation. This function is reset to zero when the engine is shut off.

Est. Range

Displays the distance that can be traveled with the displayed amount of Fuel Left and the current fuel rate (GPH) being used by the engine as received from the MG2000 SmartCraft tachometer from the engine ECU. “Fuel Tank Size”, “Fuel Tank Full” or “Amount of Fuel” must be set accurately (see above) for this function to work correctly.

Default Screen “6”



Avg Fuel Flow

Displays calculated average fuel flow in gallons per hour since “Fuel Used” was last reset. “Fuel Used” is reset in the Faria SmartCraft MG2000 tachometer.

Fuel Used

Displays calculated fuel used, since last reset, based on fuel rate (GPH) data received from the MG2000 SmartCraft tachometer from the engine ECU. “Fuel Used” is reset in the Faria SmartCraft MG2000 tachometer.

Trip

Displays trip miles since last reset. The “Trip” log can be reset in the “Edit” mode “Reset Trip Log” function.

Default Screen “7”



Fuel Level

Displays fuel level in Tank 1 as received from the MG2000 SmartCraft tachometer from the engine ECU. This is fuel level sender information. The fuel level sender should be calibrated as described in the Faria SmartCraft MG2000 tachometer manual.

Steer Angle (only applicable to inboard applications)

Displays steering angle as received from the MG2000 SmartCraft tachometer from the engine ECU.

Speed

Displays current speed in water from pitot tube and/or paddle wheel as received from the MG2000 SmartCraft tachometer from the engine ECU.

LCD Display Screens:

In “Normal” mode, press “Mode” once to enter screen “Select” mode, press “Up” or “Down” to move between screens. Press “Mode” once to return to “Normal” mode.

Select Mode

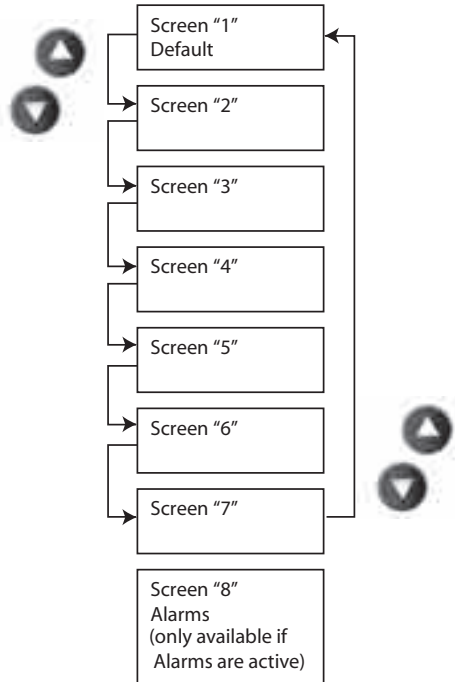
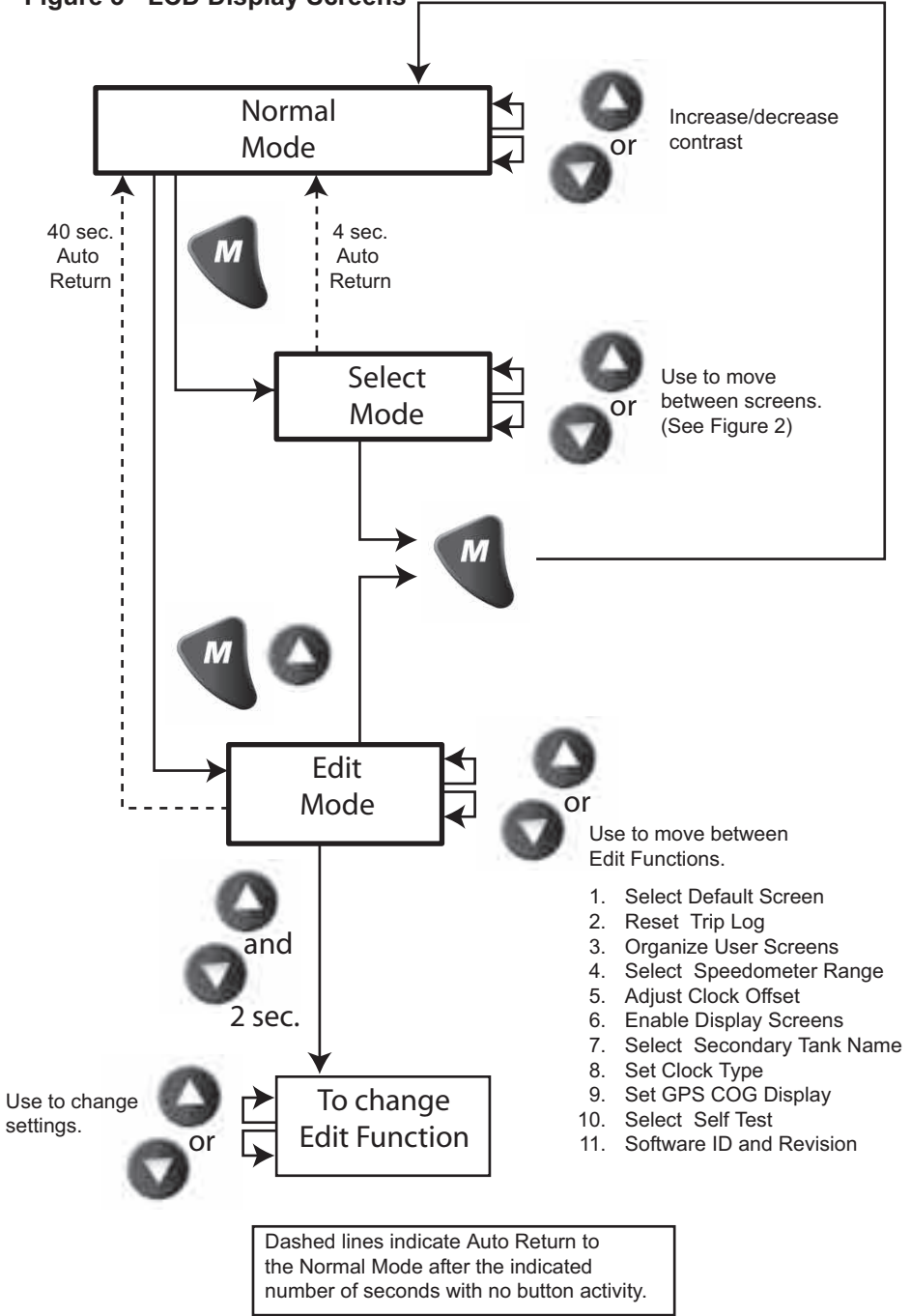
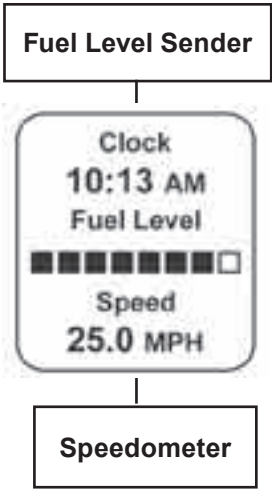

Figure 2

Figure 3 - LCD Display Screens





Fuel Functions

Fuel Level Sender

The FUEL LEVEL SENDER provides the information displayed in the Fuel Level bar graph. This display is the equivalent of a standard fuel gauge and should be used as the reference for the fuel remaining.

Each filled block represents 1/8 of a tank and when the fuel tank is empty only empty blocks will be displayed. For best accuracy, the fuel level sender should be calibrated as described in the MG2000™ tachometer manual.

Manual settings

The “Fuel Left” and “Range” display values are dependant on accurately setting the values for “Fuel Tank Size” and either “Fuel Tank Full” or “Amount of Fuel” in the MG2000™ tachometer.

“Fuel Left” is calculated based on the amount of fuel entered in these settings (the amount of fuel the operator indicates is in the fuel tank) and the fuel flow of the engine. “Range” is calculated based on “Fuel Left”, fuel flow, and current speed.

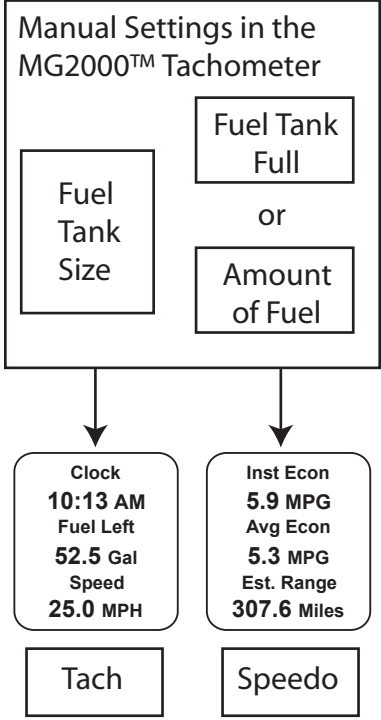

COG (Course Over Ground)

If deviation information is not available from the connected GPS, the COG display will default to the display shown at left. This is the normal display with COG indicated as it would be displayed on a compass. If desired, True North data can be displayed by selecting it in the “set GPS COG display” in the edit mode.



If deviation information is available from the GPS, the COG display can be selected to display the screen shown at left. The display will flash slowly to ensure the operator is aware that the display is showing True North bearing. True North bearing is different from Magnetic North bearing by the amount of magnetic bearing deviation at the boat's current location. Please ensure that the local magnetic deviation is taken into account if this display is to be used for navigation.

This page left blank intentionally.

Nominal current draw (tachometer, speedometer, and five 2" gauges with lights on maximum level): 420 mA

Edit Mode

The "Edit" mode is used to adjust or set the values of functions and options in the MG2000 speedometer. The following procedures specifies the steps to be taken in the "Edit" mode to adjust / set each option.

To enter "Edit" mode, press the "Mode" and "Up" buttons while in "Normal" mode.



To return to "Normal" mode, press "Mode" button once while in "Edit" mode.



Functions that are set or adjusted in the "Edit" mode

1. Select Default Screen
2. Reset Trip Log
3. Organize User Screens
4. Adjust Clock Offset
5. Enable Display Screens
6. Set Clock Type
7. Set GPS COG Display
8. Select Self Test
9. Software ID and Revision

| Instructions – <u>Function</u> | LINE | Display |
|---|------|----------|
| <u>Select Default Screen</u> | 1 | Select |
| | 2 | Default |
| | 3 | Screen |
| <p>Press and hold the “Up” <u>and</u> “Down” buttons for 2 seconds to select the “Default Screen” function.</p> <p>Press “Down” to select another function or “Mode” to return to “Normal” mode.</p> | | |
| (Display Screen 1 is the “Default” at first turn on) | 1 | Default |
| | 2 | Display |
| | 3 | Screen: |
| | 4 | 1 |
| <p>Press and hold the “Up” <u>and</u> “Down” buttons for 2 seconds to select screen 1 as the “Default Screen” and return to “Edit” mode.</p> <p>Press “Up” or “Down” to select another screen.</p> | | |
| <p>Press and hold the “Up” <u>and</u> “Down” buttons for 2 seconds to select this screen as the “Default Screen” and return to “Edit” mode.</p> <p>Press “Up” or “Down” to select another screen.</p> <p>Repeat until desired “Default Screen” is selected.</p> | 1 | Default |
| | 2 | Display |
| | 3 | Screen: |
| | 4 | X |
| <p>Press “Up” or “Down” to select another function or “Mode” to return to “Normal” mode.</p> | | |
| <u>Reset Trip Log</u> | 1 | Reset |
| | 2 | Trip |
| | 3 | Log |
| <p>Press and hold the “Up” <u>and</u> “Down” buttons for 2 seconds to reset “Trip Log” to zero (0).</p> | | |
| <p>Resets trip log to zero, changes display as shown. Press and hold the “Up” <u>and</u> “Down” buttons to return to “Edit” mode.</p> | 1 | Trip |
| | 2 | Log |
| | 3 | Reset |
| <p>Press “Up” or “Down” to select another function or “Mode” to return to “Normal” mode.</p> | | |
| <u>Organize User Screens</u> | 1 | Organize |
| | 2 | User |
| | 3 | Screens |
| <p>Press and hold the “Up” <u>and</u> “Down” buttons for 2 seconds to select “Organize User Screens.”</p> <p>Press “Up” or “Down” to select another function or “Mode” to return to “Normal” mode.</p> | | |

| | | |
|---|---|--|
| <u>Organize Screen 1</u> | 1 | Set up Screen 1 |
| | 2 | |
| | 3 | |
| Press and hold the “Up” and “Down” buttons for 2 seconds to select the “Organize Screen 1” function. Press “Up” or “Down” to select another screen or “Mode” to return to “Edit” mode. | | |
| | 1 | Screen 1 Line 1 Function Disp. Data |
| | 2 | |
| | 3 | |
| | 4 | |
| | | |
| | 1 | Screen 1 Line 2 Function Disp. Data |
| | 2 | |
| | 3 | |
| | 4 | |
| | | |
| | 1 | Screen 1 Line 3 Function Disp. Data |
| | 2 | |
| | 3 | |
| | 4 | |
| | | |
| | 1 | Set up Screen 1 |
| 2 | | |
| 3 | | |
| <i>Repeat for remaining screens (2, 3, etc).</i> | | |
| Press “Up” or “Down” to select another function or “Mode” to return to “Normal” mode. | | |
| | | |

| | | |
|---|---|--|
| <u>Select Adjust Clock Offset</u> | 1 | Adjust Clock Offset |
| | 2 | |
| | 3 | |
| <p>Press and hold the “Up” <u>and</u> “Down” buttons for 2 seconds to select the “Adjust Clock Offset” function.</p> <p>Press “Up” or “Down” to select another function or “Mode” to return to “Normal” mode.</p> | | |
| <p>Press “Up” or “Down” to adjust the clock offset value.</p> <p>Press and hold the “Up” <u>and</u> “Down” buttons for 2 seconds to save the clock offset and return to “Edit” mode.</p> <p>Note: If the local time zone changes, this adjustment must be repeated.</p> | 1 | Adjust Clock Offset Hours X |
| | 2 | |
| | 3 | |
| | 4 | |
| | 5 | |
| <p>Press “Up” or “Down” to select another function or “Mode” to return to “Normal” mode.</p> | | |
| <u>Select Enable Display Screens</u> | 1 | Enable Display Screens |
| | 2 | |
| | 3 | |
| <p>Press and hold the “Up” <u>and</u> “Down” buttons for 2 seconds to select the “Enable Display Screens” function.</p> <p>Press “Up” or “Down” to select another function.</p> | | |
| <p>A box will appear around “On” if this display screen is “On.”</p> <p>Press and Hold “Up” <u>and</u> “Down” to switch the box to the “Off” position. When the unit is returned to “Normal” mode, Display 1 will not be displayed.</p> <p>Press “Up” to select the next display to be turned “On” or “Off.”</p> <p>Refer to Figure 1 for display screen contents which will vary with engine type. Screen 1 shown is for reference purposes only.</p> <p>When all display screens have been set “On” or “Off”, press “Down” to cycle back through the display screens if required.</p> <p>Press “Mode” to return to “Edit” mode.</p> | 1 | Enable Display 1 <div style="border: 1px solid black; display: inline-block; padding: 2px;">On</div> Off Clock Fuel Level Speed |
| | 2 | |
| | 3 | |
| | 4 | |
| | 5 | |
| | 6 | |
| <p>Press “Up” or “Down” to select another function or “Mode” to return to “Normal” mode.</p> | | |
| <u>Select Set Clock Type</u> | 1 | Set Clock Type |
| | 2 | |
| | 3 | |
| <p>Press and Hold the “Up” <u>and</u> “Down” buttons for 2 seconds to select the “Set Clock Type” function.</p> <p>Press “Up” or “Down” to select another function.</p> | | |

| | | |
|--|---|---|
| <p>Press “Up” or “Down” to scroll through the selections.</p> <p>When the correct choice is next to the selection arrow.</p> <p>Press and hold the “Up” <u>and</u> “Down” buttons for 2 seconds to save the selection and return to “Edit” mode.</p> | 1 | Set Clock Type 24 Hour >12 Hour |
| | 2 | |
| | 3 | |
| | 4 | |
| | 5 | |
| Press “Up” or “Down” to select another function or “Mode” to return to “Normal” mode. | | |
| <p style="text-align: center;"><u>Select Set GPS COG Display</u></p> | 1 | Set GPS COG Display |
| | 2 | |
| | 3 | |
| Press and hold the “Up” <u>and</u> “Down” buttons for 2 seconds to select the “Set GPS COG Display” function. Press “Up” or “Down” to select another function. | | |
| <p>Press “Up” or “Down” to scroll through the selections.</p> <p>When the correct choice is next to the selection arrow, Press and hold the “Up” <u>and</u> “Down” buttons for 2 seconds to save the selection and return to “Edit” mode.</p> | 1 | Set GPS COG Display True North >Magnetic |
| | 2 | |
| | 3 | |
| | 4 | |
| | 5 | |
| Press “Up” or “Down” to select another function or “Mode” to return to “Normal” mode. | | |
| <p style="text-align: center;"><u>Select Self Test</u></p> | 1 | Select Self Test |
| | 2 | |
| | 3 | |
| Press and hold the “Up” <u>and</u> “Down” buttons for 2 seconds to select “Self Test” Press “Up” or “Down” to select another function. | | |
| <p style="text-align: center;">This screen will display for 10 seconds, the backlights and warning lights will flash three times.</p> | 1 | Self Test Faria MG2000 SW ID + Rev. PGFXXXXXX Date |
| | 2 | |
| | 3 | |
| | 4 | |
| | 5 | |
| | 6 | |
| When the “Self Test” is complete the unit will return to the “Edit” mode. | | |
| Press “Up” or “Down” to select another function or “Mode” to return to “Normal” mode. | | |

Select Software ID and Revision

| | |
|---|--------------|
| 1 | SW ID + Rev. |
| 2 | Faria |
| 3 | MG2000 |
| 4 | Speedometer |
| 5 | PGFXXXXXX |
| 6 | Date |

Press “Up” to select another function or “Mode” to return to “Normal” mode.

Alarm Mode

Alarm Screen (Showing both alarms)

The “Alarm Screen” appears only if an alarm condition exists. The alarm condition may be a warning sent from the engine ECU or a “local” alarm such as “Low Fuel”. When an alarm condition occurs, the “Alarm Screen” will appear and the screens described below will be displayed.

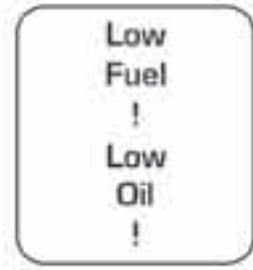

The descriptions below also explain how to temporarily override the alarm screen and visual warnings and return to “Normal” mode. In all cases, the alarm will re-occur after a period of time to ensure that the user remembers the alarm condition. Once an alarm condition has been corrected, the alarm screen, and warning lights will no longer be displayed.

Figure 4

| Alarm Mode | Line | Display |
|---|------|-------------------------------------|
| <p>The “Alarm Screen” will appear if an alarm condition occurs.</p> <p>The alarms that appear in the Speedometer are “Low Fuel” and Low Oil Reserve.</p> | | |
| <p style="text-align: center;">Low Fuel – Low OIL</p> <p>Displays applicable warning (both if present)</p> <p>“Low Fuel” – Fuel level is critically low.</p> <p>“Low Oil” Level (Outboard 2 stroke only) – Oil level in the remote tank is low.</p> <p>Red Warning LED’s blinks.</p> | 1 | Low Fuel ! Low Oil ! |
| | 2 | |
| | 3 | |
| | 4 | |
| | 5 | |
| <p>Press “Mode” then push “Up” to turn off the Warning LED’s and return to “Run” mode. Alarm will reactivate in 10 to 15 minutes but can continue to be deactivated as required.</p> | 6 | |

Harness HN0403

SmartCraft

Tachometer Cable

(To connect from the SmartCraft harness to the junction box.)

SmartCraft
MG2000 Tachometer

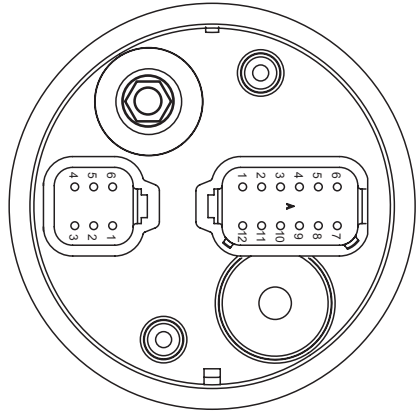

12- pin connector

| | | |
|--------|----------|----------------|
| Pin 1 | Red | Faria Bus |
| Pin 2 | White | Faria Bus |
| Pin 3 | Green | Faria Bus |
| Pin 4 | Black | Faria Bus |
| Pin 5 | Violet | Ignition(Wake) |
| Pin 6 | Not Used | |
| Pin 7 | Not Used | |
| Pin 8 | Not Used | |
| Pin 9 | Not Used | |
| Pin 10 | Black | Not Used |
| Pin 11 | Red | CAN 1 + |
| Pin 12 | White | CAN 1 - |

4- pin connector

| | |
|-------|----------------|
| Pin A | Red |
| Pin B | White |
| Pin C | Green |
| Pin D | Black & Shield |

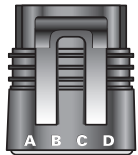

Heat Shrink Tubing

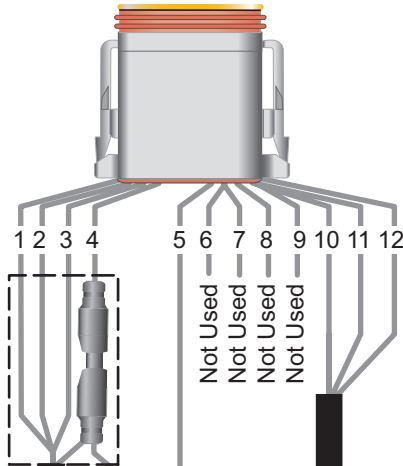

SmartCraft Cable

| | | |
|-------|----------|-----------|
| Pin A | Not Used | |
| Pin B | Black | Ground |
| Pin C | Not Used | |
| Pin D | Not Used | |
| Pin E | Not Used | |
| Pin F | Violet | (Wake Up) |
| Pin G | Not Used | |
| Pin H | Not Used | |
| Pin J | Red | CAN 1 + |
| Pin K | White | CAN 1 - |

Black

Violet

Heat Shrink Tubing

Violet
Black

Wire Jacket

Harness HN0403 Speedometer Cable

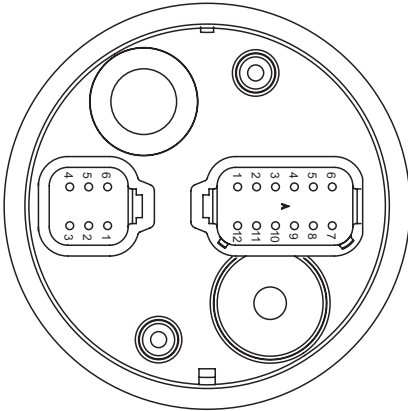

12- pin connector

| | | | |
|--------|----------|-------------|----------|
| Pin 1 | Red | Faria Bus | +8.4 VDC |
| Pin 2 | White | Faria Bus | AY |
| Pin 3 | Green | Faria Bus | BZ |
| Pin 4 | Black | Faria Bus | Ground |
| Pin 5 | Not Used | | |
| Pin 6 | Not Used | | |
| Pin 7 | Tan | Temp Signal | |
| Pin 8 | Not Used | | |
| Pin 9 | Not Used | | |
| Pin 10 | Not Used | | |
| Pin 11 | Not Used | | |
| Pin 12 | Not Used | | |

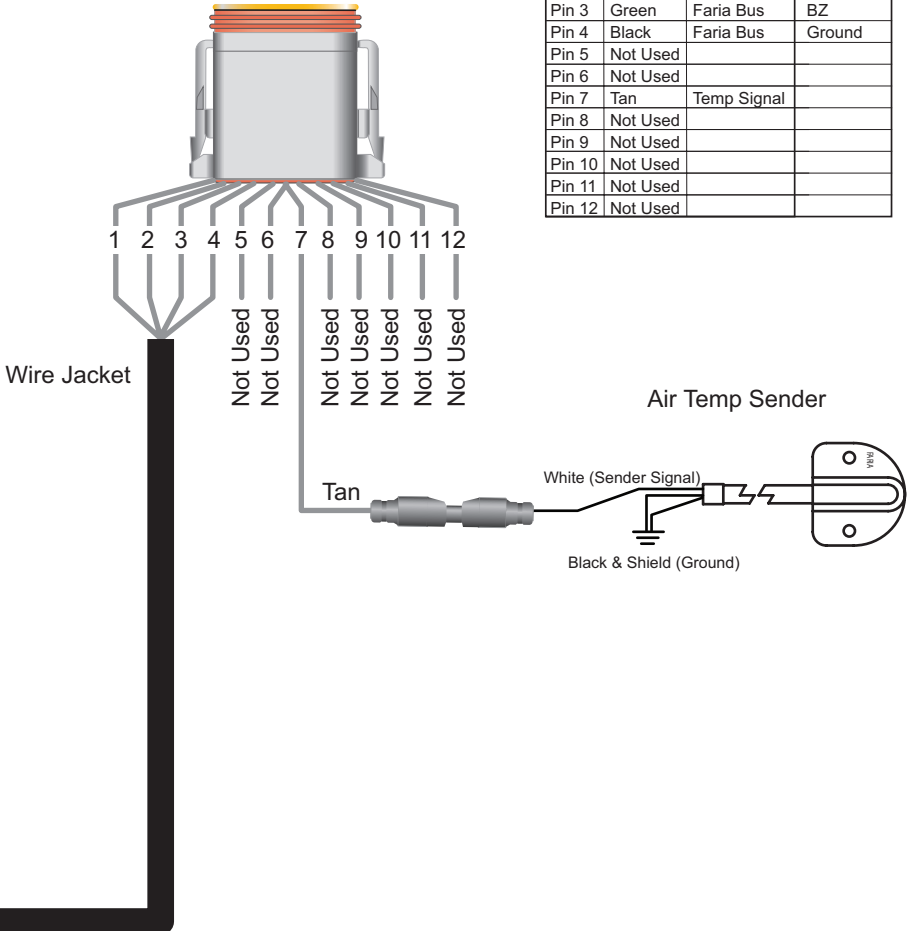

Harness HN0407

SmartCraft

Tachometer Cable

(To connect direct to the SmartCraft junction box.)

SmartCraft
MG2000 Tachometer

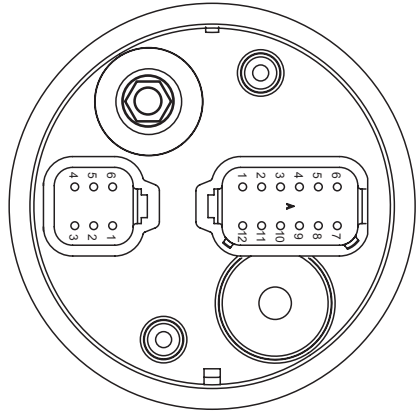

12- pin connector

| | | | |
|--------|----------|----------------|----------|
| Pin 1 | Red | Faria Bus | +8.4 VDC |
| Pin 2 | White | Faria Bus | AY |
| Pin 3 | Green | Faria Bus | BZ |
| Pin 4 | Black | Faria Bus | Ground |
| Pin 5 | Violet | Ignition(Wake) | |
| Pin 6 | Not Used | | |
| Pin 7 | Not Used | | |
| Pin 8 | Not Used | | |
| Pin 9 | Not Used | | |
| Pin 10 | Black | Not Used | |
| Pin 11 | Red | CAN 1 + | |
| Pin 12 | White | CAN 1 - | |

4- pin connector

| | |
|-------|----------------|
| Pin A | Red |
| Pin B | White |
| Pin C | Green |
| Pin D | Black & Shield |

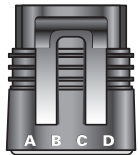

Heat Shrink Tubing

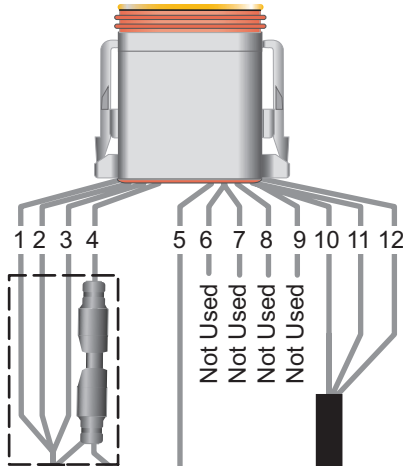

SmartCraft Cable

| | | |
|-------|----------|-----------|
| Pin A | Not Used | |
| Pin B | Black | Ground |
| Pin C | Not Used | |
| Pin D | Not Used | |
| Pin E | Not Used | |
| Pin F | Violet | (Wake Up) |
| Pin G | Not Used | |
| Pin H | Not Used | |
| Pin J | Red | CAN 1 + |
| Pin K | White | CAN 1 - |

Black

Violet

Heat Shrink Tubing

Violet
Black

Wire Jacket

Harness HN0407 Speedometer Cable

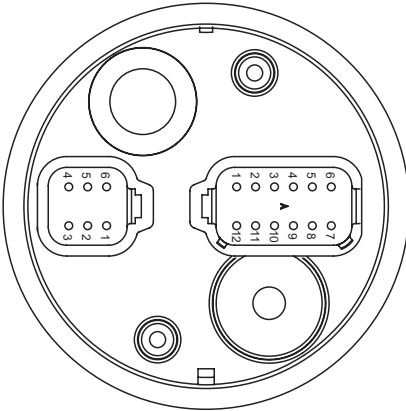

12- pin connector

| | | | |
|--------|----------|-------------|----------|
| Pin 1 | Red | Faria Bus | +8.4 VDC |
| Pin 2 | White | Faria Bus | AY |
| Pin 3 | Green | Faria Bus | BZ |
| Pin 4 | Black | Faria Bus | Ground |
| Pin 5 | Not Used | | |
| Pin 6 | Not Used | | |
| Pin 7 | Tan | Temp Signal | |
| Pin 8 | Not Used | | |
| Pin 9 | Not Used | | |
| Pin 10 | Not Used | | |
| Pin 11 | Not Used | | |
| Pin 12 | Not Used | | |

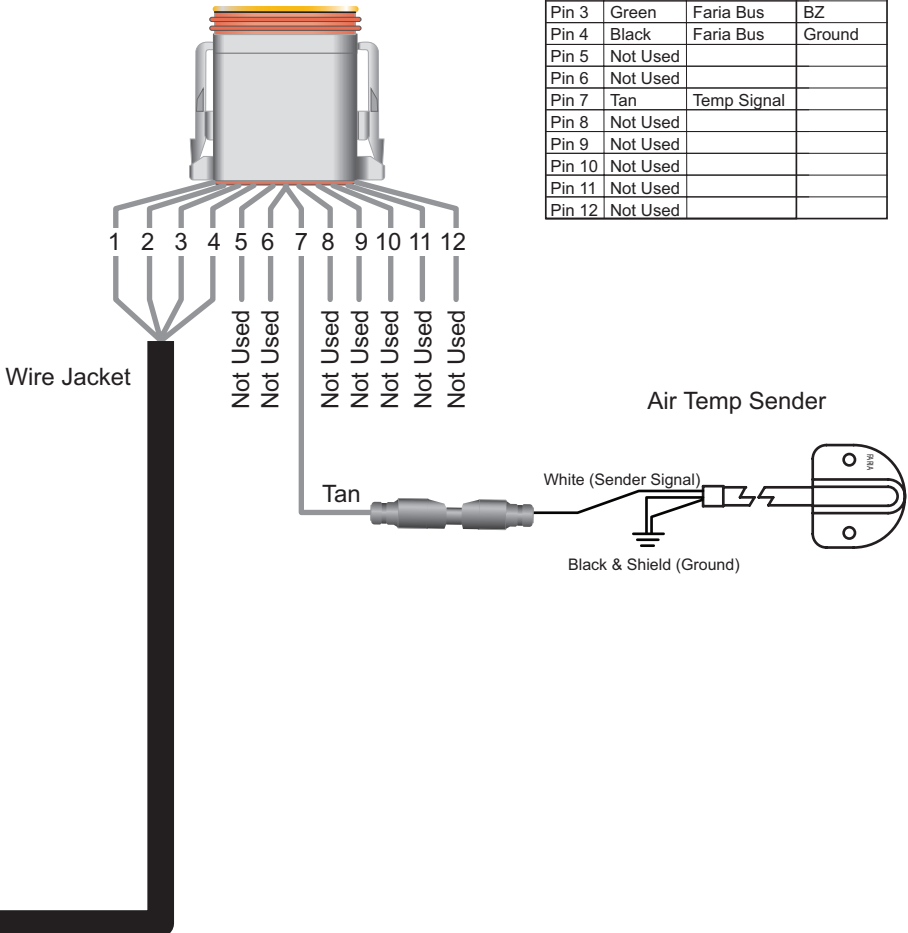

Tachometer to 2" Gauge Connection

From Tachometer

HN0503

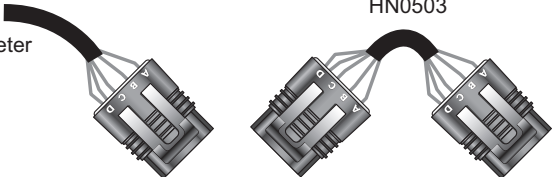

4- pin connector

| | |
|-------|----------------|
| Pin A | Red |
| Pin B | White |
| Pin C | Green |
| Pin D | Black & Shield |

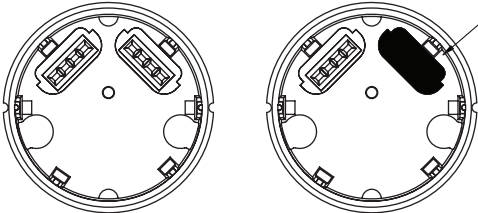

PJ0018

Note: To help reduce moisture in the gauges, be sure to install plug PJ0018 in all open connectors

2" Gauges

