

6 Gauge Box Set

IS0332

Rev. B ecr 10271 12/2015

Hot Rod Series

Part Numbers

KTF027

KTF078

Made in the USA

Caution

Disconnect the battery during installation. Tighten nuts on the back clamp only slightly more than you can tighten with your fingers. Six inch-pounds of torque are sufficient. Over tightening may result in damage to the instrument and may void your warranty. Use stranded, insulated wire not lighter than 18 AWG.

Be certain wire insulation is not in danger of melting from engine or exhaust heat or interfering with moving mechanical parts.

Parts List

Speedometer

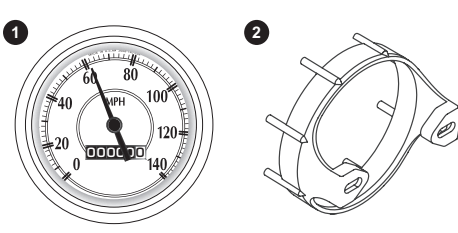
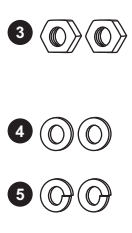
QTY	Description			
1	Speedometer - Mechanical	1		
1	Mounting Bracket	2		
1	Hardware			
2	#10 Brass Nut (3/8")	3		
2	#10 Brass Flat Washer	4		
2	#10 Split Washer	5		

Tachometer

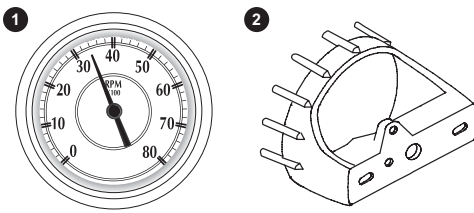
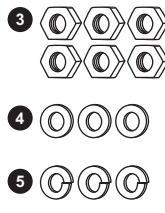
QTY	Description			
1	Tachometer	1		
1	Mounting Bracket	2		
1	Hardware			
6	#10 Brass Nut (3/8")	3		
3	#10 Brass Flat Washer	4		
3	#10 Split Washer	5		

Fuel Level Gauge

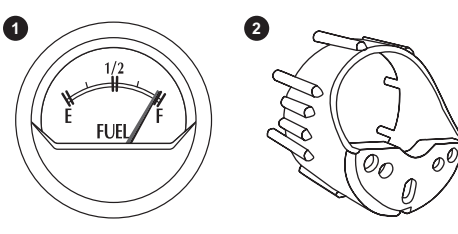
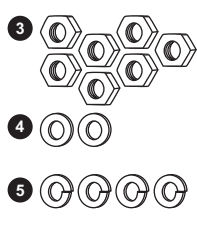
QTY	Description			
1	Fuel Level Gauge	1		
1	Mounting Bracket	2		
1	Hardware			
7	#10 Brass Nut (3/8")	3		
3	#10 Brass Flat Washer	4		
4	#10 Split Washer	5		

Voltmeter

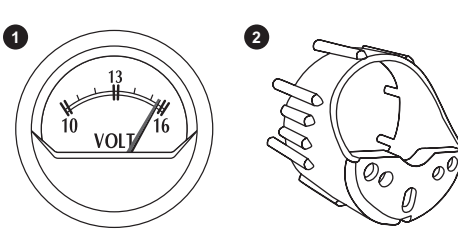
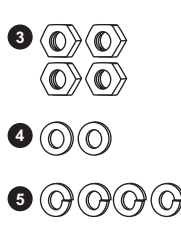
QTY	Description			
1	Voltmeter	1		
1	Mounting Bracket	2		
1	Hardware			
4	#10 Brass Nut (3/8")	3		
2	#10 Brass Flat Washer	4		
2	#10 Split Washer	5		

Water Temperature Gauge

QTY	Description	
1	Water Temperature Gauge	1
1	Mounting Bracket	2
1	Hardware	
6	#10 Brass Nut (3/8")	3
3	#10 Brass Flat Washer	4
3	#10 Split Washer	5

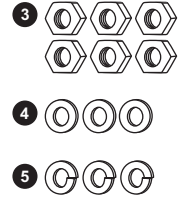
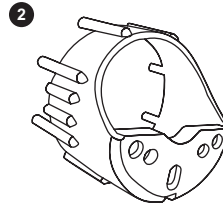
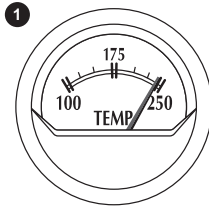

Oil Pressure Gauge

QTY	Description	
1	Oil Pressure Gauge	1
1	Mounting Bracket	2
1	Hardware	
7	#10 Brass Nut (3/8")	3
3	#10 Brass Flat Washer	4
4	#10 Split Washer	5

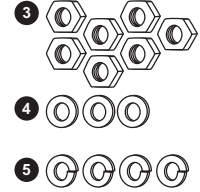
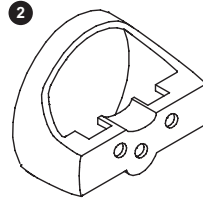
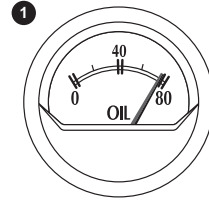

Fuel Level Sender

QTY	Description	
1	LS1038 - Standard 240-33 Ohms	1
1	HW-184 - Hardware Kit	
1	GK0093 - Gasket	2
3	#8 Brass Nut (5/16")	3
3	#8 Split Washer	4

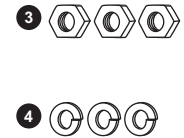
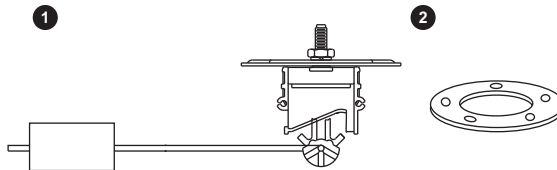

Pressure Sender

QTY	Description	
1	SD0006 - Pressure Sender	1
1	Brass Nut (3/8")	2
1	Brass Flat Washer	3

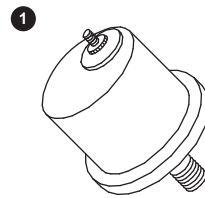

Temperature Sender

QTY	Description	
1	TS1029 - Temp Sender	1
1	BS0005 - 1/2 to 1/8 NPTF	2
1	AD0048 - 1/8 to 1/4 NPTF	3
1	BS0003 - 1/8 to 3/8 NPTF	4
1	Hardware	
1	#10 Brass Nut (3/8")	5
1	#10 Split Washer	6

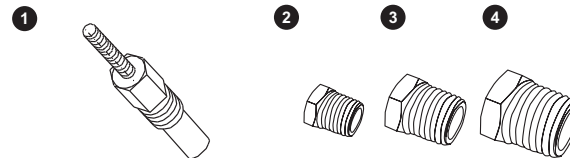

Light Bulb Replacement

Speedometer	GE No. 194
Tachometer	GE No. 194
Fuel Level Gauge	GE No. 658
Voltmeter	GE No. 658
Water Temperature Gauge	GE No. 658
Oil Pressure Gauge	GE No. 658

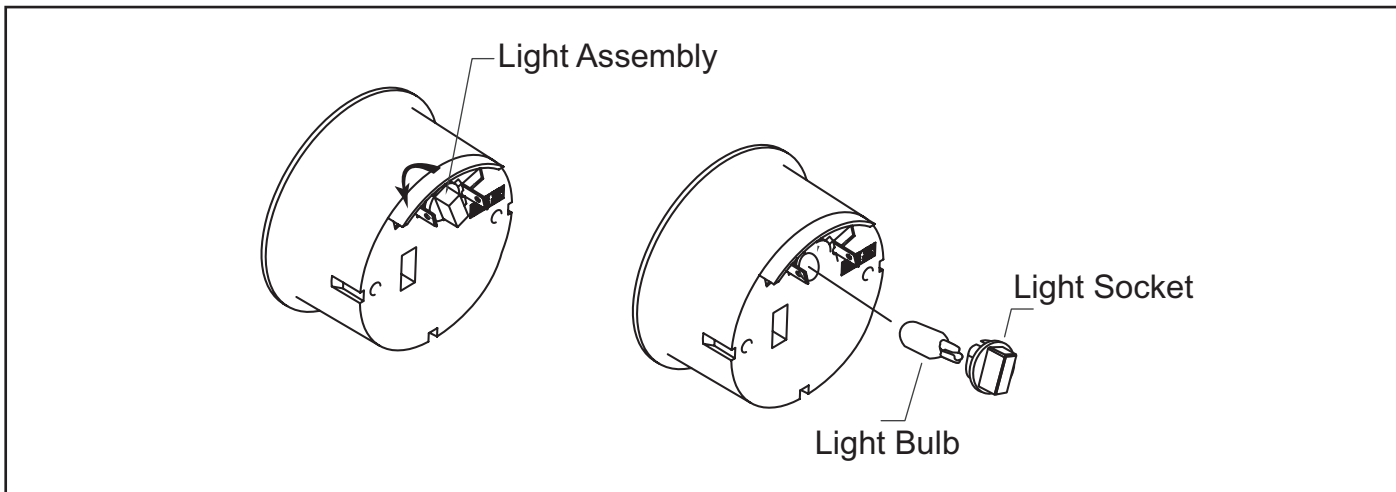

Installation

- 1 Disconnect the negative battery terminal.
- 2 If you are not replacing an existing gauge in the dash, locate a mounting location for the gauge(s) that provide easy readability from the operator's position. Verify there is enough workable space behind the mounting location to install your gauge and make connections if necessary.
- 3 Cut a hole in the dash for each gauge. Use the chart to determine the correct hole size.
- 4 Install the gauge in the mounting hole and check fit.
- 5 Mount the gauge(s) with the mounting brackets using the split washers and brass nuts as shown on the next page. Tighten the nuts finger tight using only 6 inch pounds of torque.

Gauge	Hole Size
Speedometer	85 mm (3.375 in)
Tachometer	85 mm (3.375 in)
Fuel Level	53 mm (2.063 in)
Voltmeter	53 mm (2.063 in)
Water Temperature	53 mm (2.063 in)
Oil Pressure	53 mm (2.063 in)

Warning

Do not over tighten the mounting nuts. Over tightening the nuts may crack the gauge housing, mounting bracket or mounting panel.

- 6 It is recommended that insulated wire terminals, preferably ring type be used on all connections. Light assembly connections require 6 mm (.25 in) female blade terminal.

Voltmeter Connections

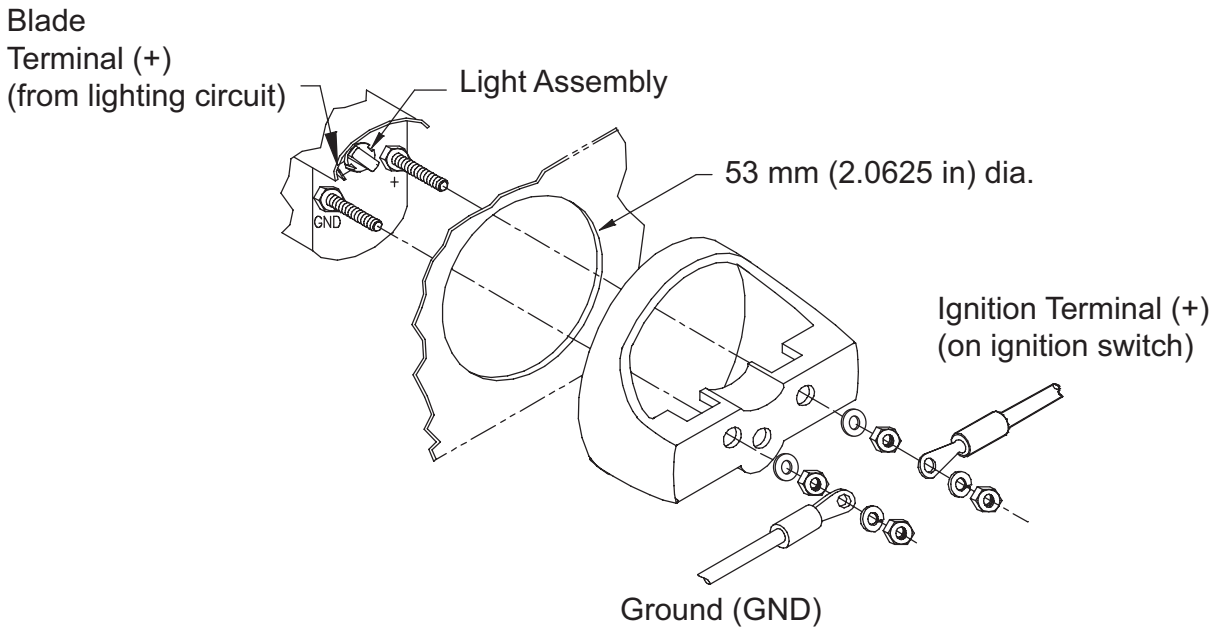

Fuel Level Gauge Connections

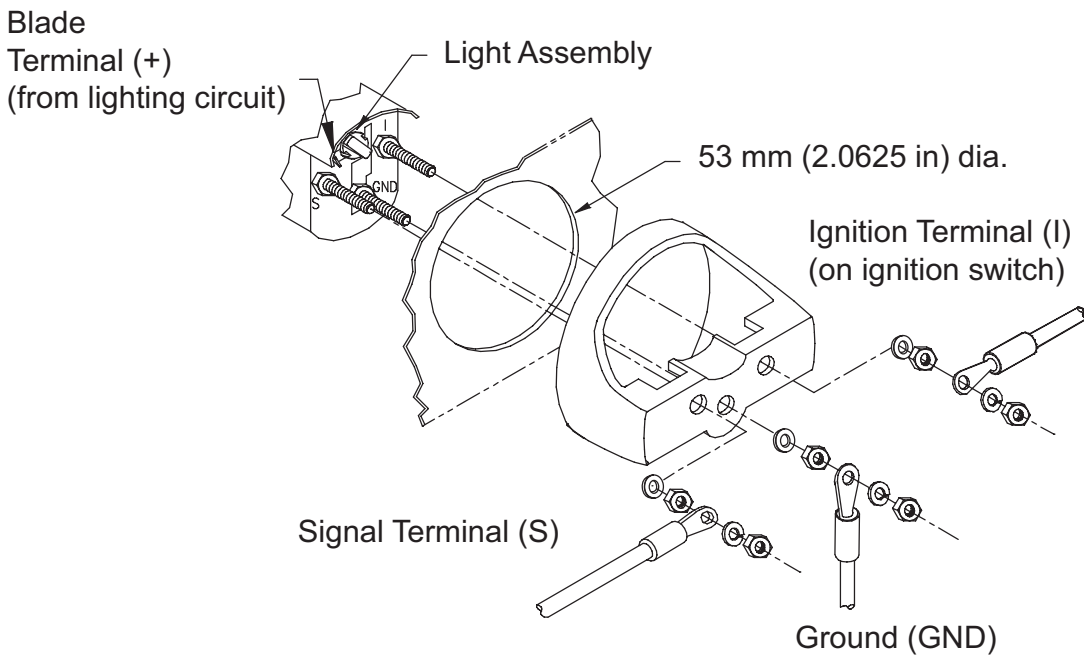

Special Caution should be taken when working on or around tanks that have, or have had fuel in them.

Water Temperature Gauge Connections

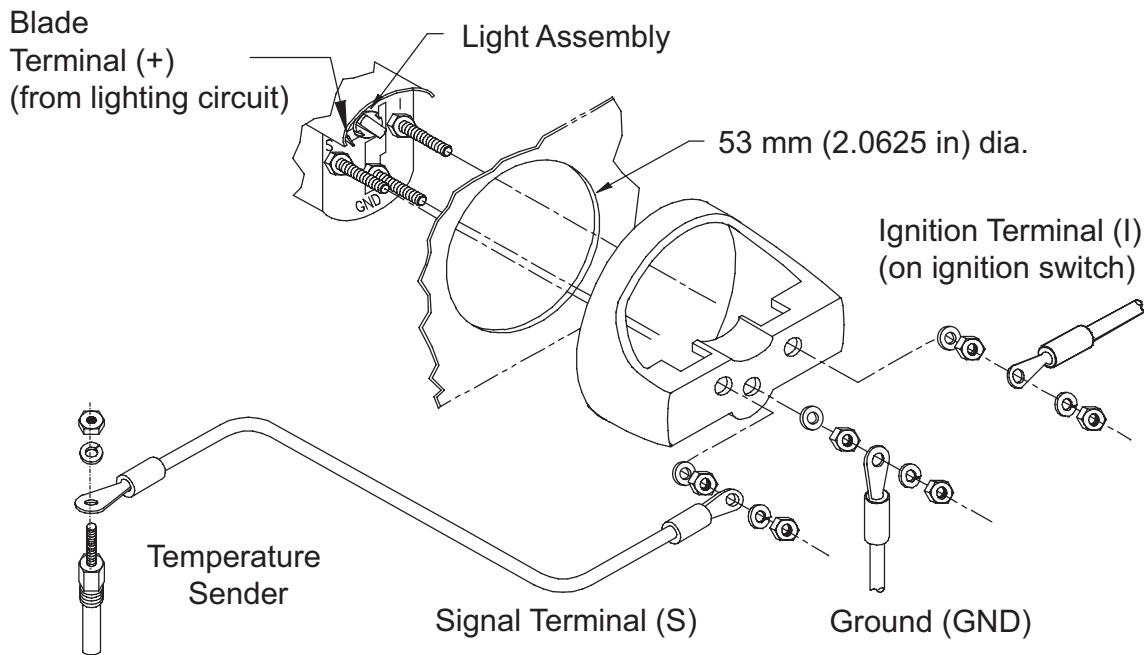

Oil Pressure Gauge Connections

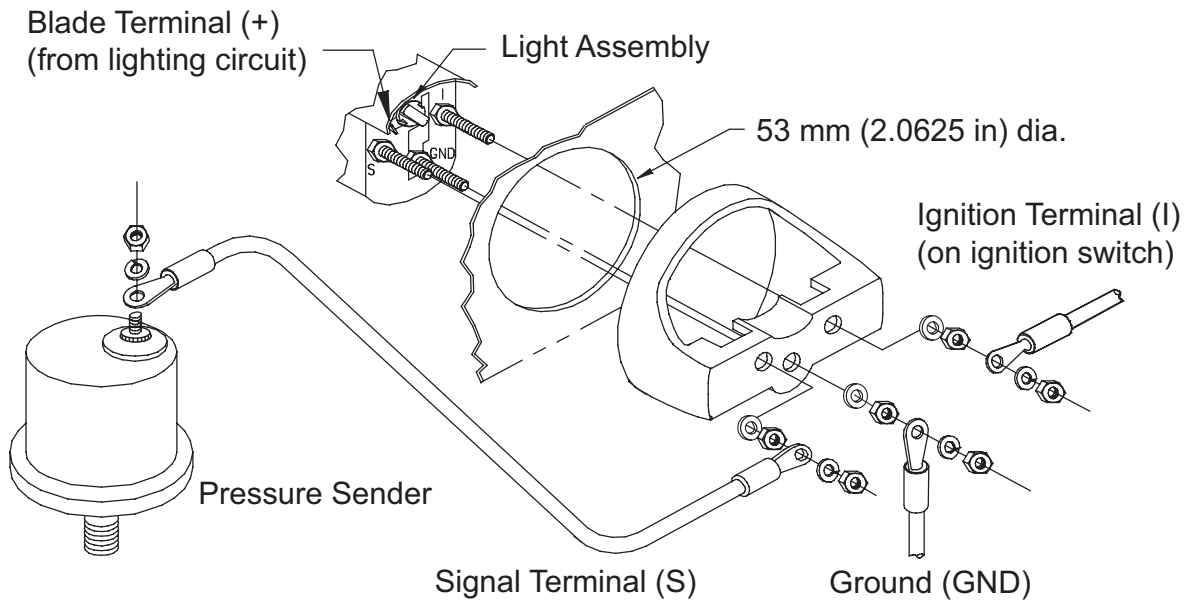

Tachometer Connections

Blade Terminal (+)
(from lighting circuit)

Light Assembly

85 mm (3.375 in) dia.

Adjustment Pot

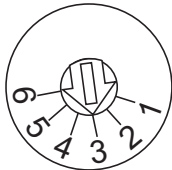

Engine	Setting
4 CYL	1
6 CYL	2
8 CYL	3

Ignition Terminal (+) (BAT)
(from ignition switch)

Signal (SIG)

Ground (GND)

Tachometer Selector Switch Setting

Using a small screwdriver, SLIGHTLY depress and turn the selector switch on the back of the tachometer to the correct position to match the number of cylinders (see label on the side of the tachometer). Depressing the switch too hard may cause damage to the tachometer!

Be sure the selector switch has locked into the correct position by slightly rotating the switch back and forth with the screwdriver.

Refer to your vehicle's manual for the wiring schematic to determine where the tachometer signal is on application with a coil pack. (Found in most automotive stores.) The Tachometer may be hooked up to the negative lead on the ignition coil for Tachometer signal.

Speedometer Connections

Blade Terminal (+)
(from lighting circuit)

Light Assembly

Blade Terminal (-)
(Ground)

85 mm
(3.375 in) dia.

Speedometer
Cable

Installing the Fuel Level Sender

Standard Fuel Level Sender 240-33 Ohms

Warning

Read all instructions thoroughly before installation. If you are not experienced in working with fuel tanks, seek professional assistance. Disconnect battery before proceeding! Any type of work involving fuel tank repair or modification should be performed with extreme care. Due to the possibility of igniting fuel fumes, the tank should be empty, dry, and purged of fumes. Work should be performed in a well ventilated area. Only tools that will not create possible fuel ignition sparks should be used. Failure to comply with installation instructions may result in unsatisfactory instrument performance. Improper installation or use of the product for an application other than its intended use will void your warranty and could result in serious personal injury.

Tools You Will Need

Tape Measure
Hacksaw
3/8" Wrench

Part I: Adjusting the Sender

1. Measure the depth of the tank down through the large hole.
2. Allow the Float Arm to hang down loosely so that the float hangs just above the tank bottom. See Illustration A. Measure the length of the Float Arm. If the Float Arm is too long you must cut off the excess with a hacksaw.

Illustration A

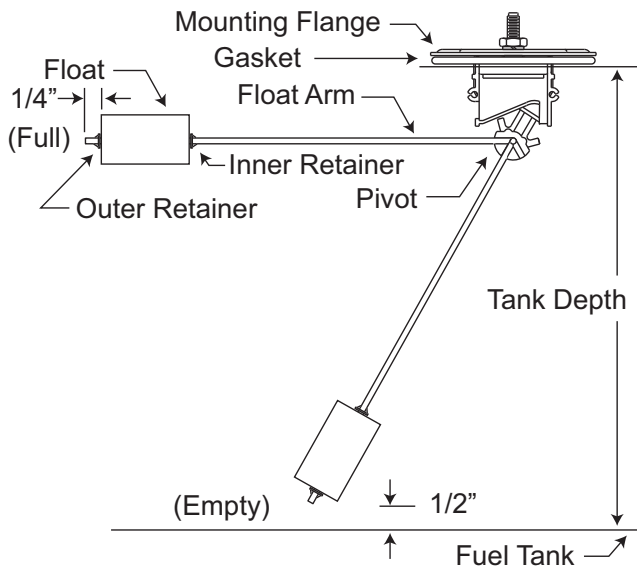

3. Slide the Float and both Retainers toward the Pivot along the Float Arm to the desired length. Leave about 1/4 inch of the arm beyond the Outer Retainer and cut off the excess. Do not position the Inner Retainer at this

time.

4. Insert the Float and Float Arm assembly into the tank hole, and lower the sender until the mounting flange makes contact with the top of the tank. Make sure the flange is positioned flat against the tank. The Float should hang freely and not contact the bottom of the tank. If the float contacts the bottom of the tank, slide the Float and the Retainer 1/4 inch up the arm towards the Pivot and trim the excess as in step 3. Try the fit again, and repeat this step as necessary for the Float to hang freely. Now you may slide the Inner Retainer against the Float.

Part II: Installing the Sender

1. Place the gasket on the tank top and rotate it until all the holes align properly. Lower the float into the tank and lower the sender until the mounting flange is flat on the gasket and all the holes align properly.

Important

Use only the Faria gasket supplied with the level sender. The use of any other gasket could effect the function of the sender, result in damage to the sender or may not provide a reliable seal between the tank and sender.

NOTE: If you find that when aligning the holes, the float arm hits the tank side, a baffle, or a pick-up tube, it will be necessary to rotate the float arm. (In most applications the float arm should point forward).

2. Gently turn all the screws or nuts until they just contact the mounting flange. Snug the screws or nuts in opposite sequence. If you do this in several stages it will ensure that the mounting flange evenly compresses the gasket. Do not overtighten as you may strip out threads in tank top.

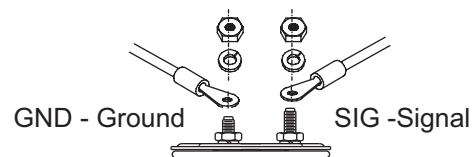

3. Connect the end of the black ground wire to ground (GND). Connect the signal wire (SIG) to the signal wire of the gauge. Your installation is now complete.

Caution

Observe the fuel tank during initial operation to be sure there are no leaks!

Oil Pressure Senders

Engines or transmissions equipped with a low oil pressure switch that activates a warning light require an appropriate "T" pipe fitting to accommodate both pressure sender and warning light. Most oil pressure sending units have 1/8" NPT pipe threads and are usually mounted in the engine's block. If the block or transmission case has a larger pipe size, an appropriate bushing may be used without affecting pressure- sensing accuracy.

Temperature Senders

Temperature senders are available from Faria® Performance Instruments in 1/8" NPT thread sizes. If your water jacket, oil pan or transmission housing requires a thread diameter larger than 1/8" NPT, a bushing will be required. "T" fittings should NOT be used as these may affect the accuracy of the sender by reducing the temperature signal.

Sender Specifications

Temperature Sender:	100°F (450 Ω) to 250°F (29.6 Ω)
Fuel Level Sender:	E(240 Ω) - F (33.5 Ω)
Oil Pressure:	0 PSI (240 Ω) - 80 PSI (33.5 Ω)

SD0047 (Faria part#) may be used for Speedometer sensor.
Mount to bell housing to count flywheel teeth.

DK9005 (Faria part#) Hooks up to mechanical take off on transmission.